



BOOTSTRAPPING ANALYSIS OF NORTH SUMATRA PROVINCE INSPECTORATE PERFORMANCE

Daniel Ebenezer Silaban✉¹, Irsad Lubis²

Universitas Sumatera Utara

✉ danielsilaban17@gmail.com

Jl. Dr. T. Mansur No.9, Padang Bulan, Medan, Sumatera Utara 20222

Abstract

The goal of this study is to analyze the factors that influence how well the inspectorate in the province of North Sumatra performs. This research is important because it aims to evaluate the performance of the inspectorate's officials and staff in North Sumatra Province so that measures may be taken to raise employee professionalism and quality. The Smart PLS program was employed as the basis for the quantitative research approach. The research subjects were 48 officials and workers in the functional position of auditors who were taken using the Slovin technique. The results indicate that the inspectorate of the North Sumatra Province performs poorly, particularly when it comes to the implementation of good governance and leadership commitment, where indirect good governance has not been able to mediate leadership commitment.

Keywords: inspectorate; bootstrapping; good governance; leadership commitment; profesionalism

Article Info

History of Article
Received: 08/10/2022
Revised: 05/01/2023
Published: 22/02/2023

Jurnal Riset Bisnis dan Manajemen
Volume 16, No. 1, February 2023,
Page 83-90
ISSN 2088-5091 (Print)
ISSN 2597-6826 (Online)

INTRODUCTION

An institution's inspectorate is one of the divisions tasked with carrying out inspection and supervision. The inspectorate is essential in preserving service quality and making sure that all actions are carried out in compliance with the laws that are in force (Dyhati & Wahyudi, 2022; Rahayu et al., 2020). Also, the inspectorate plays a significant role in preventing and resolving issues inside an institution such as corruption, noncompliance, and failure to do their tasks (Edi & Enzelin, 2022). The inspectorate must thus possess the necessary capability and expertise to appropriately perform its tasks.

A variety of factors, including sufficient human resources, suitable technology, and facilities, as well as effective work methods and procedures, have a significant impact on inspectorate performance (Dewi et al., n.d.; Muhammad, 2017; Suhayati, 2022). In order for the inspectorate to effectively perform its functions, it must have qualified people, resources, and the necessary infrastructure and technology. In general, the performance of the inspectorate is very important to maintain service quality and ensure that every action taken is in accordance with applicable regulations (Dyhati & Wahyudi, 2022; Rahayu et al., 2020; S et al., 2020). Good inspectorate performance can help maintain the integrity and professionalism of the institution and ensure that every action taken within the institution is correct and in accordance with applicable regulations.

Nonetheless, the inspectorate often faces a variety of problems that prevent the development of a professional and competent performance. According to Suwiryo and Samsudin (2021), among the issues that frequently affect inspectorate performance are: (i) the inspectorate's employees' inadequate human resources, which prevents them from carrying out their duties properly; (ii) technological and facility constraints, which will have a detrimental effect on the standard of inspection and supervision performed by the inspectorate; (iii) systems and work procedures that are less effective; (iv) systems and work procedures that are corrupted or have

conflicts of interest that will affect the integrity and professionalism of inspectorate employees; and (v) a lack of support from external parties, such as the government or related institutions, for the inspectorate's working.

According to the secretary of the North Sumatra Province Inspectorate (SUMUT), some of the issues described above may also be apparent in how the North Sumatra Inspectorate performs, particularly with regard to local government finance management (PEMDA). Because of the numerous discoveries of irregularities in local government financial management, the performance of the government's external monitoring agencies, such as the Supreme Audit Agency (BPK), appears to be becoming increasingly important (Rumaijuk, 2011: 1).

The budget for managing COVID-19 was one of 121 findings in the North Sumatra Province Government's financial report for 2020. 24 regional loss findings and 97 administrative findings make up the number of recommendations. Among them, 20 (83.3%) regional loss results and 71 (73.19%) administrative findings have received follow-up. As of January 12, 2021, there are four discoveries that are being followed up on the basis of the government's financial report for 2020. 24 regional loss findings and 97 administrative findings make up the number of recommendations. Among them, 20 (83.3%) regional loss results and 71 (73.19%) administrative findings have received follow-up. As of January 12, 2021, there are four discoveries that are being followed up on. Some of the overall conclusions have to do with how the COVID-19 pandemic is handled (Pencawan, 2021:1).

According to the conclusions reached by the BPK in 2020, the auditors at the Inspectorate of North Sumatra Province did not perform at their best. A lack of implementation of good governance, a lack of leadership commitment, and the auditor's own role all point to suboptimal performance. Even though these three factors are crucial for enhancing performance at the North Sumatra Provincial Inspectorate. The issue of human resources for the supervisory apparatus inside the inspectorate itself is something that the inspectorate of North Sumatra Province also encounters when doing their tasks. The unequal specification of the scientific domains they have leads to a variety of issues with human resources, including the inspectorate's restricted capacity to perform their tasks as field supervisors. An important step in raising the caliber of each institution's performance is scientific human resource development, which must be implemented. It is imperative to conduct scientific human resource development within a formal organization's bureaucracy, particularly given that development is the focus of government. Due to the poor human resource capability, government organizations will ultimately only make a little contribution toward attaining their aims (Vadilla, 2013: 56).

The aforementioned performance issues with the inspectorate will have an impact on the standard of the inspection and supervision services provided by the inspectorate as well as their personal integrity and professionalism (Bastian, 2019; Dewi et al., n.d.; Muhammad, 2017; S et al., 2020; Suhayati, 2022; Usman et al., 2016; Yendrawati et al., 2013). Thus, a remedy is required to address these issues and enhance the inspectorate's effectiveness. Based on the issue and facts stated above, this study aims to conduct a bootstrapping analysis of the performance of the inspectorate of North Sumatra Province.

METHOD

This study employs a quantitative methodology with an analysis of the approach path (Saptomo & Rimawati, 2020; Tiro et al., 2020). This strategy was used to examine the direct and indirect effects of the variables affecting the inspectorate's performance. The function of the auditor, leadership commitment (Islam et al., 2018; Jain & Duggal, 2018; Knotts & Houghton, 2021; Mesu et al., 2015; Saleem et al., 2019), good governance and indirect effects of the variables affecting the inspectorate's performance. The function of the auditor, leadership commitment (Islam et al., 2018; Jain & Duggal, 2018; Knotts & Houghton, 2021; Mesu et al., 2015; Saleem et al., 2019), good governance (O'Leary & Stewart, 2007; Park et al., 2019; and Steyn, 2020), and transparency are the elements that impact inspectorate performance in this study.

Path analysis, which was utilized in this study, is a method for examining causal relationships in which the independent variable has both direct and indirect effects on the dependent variable. In other words, this study aims to determine the direct and indirect effects of independent factors on the performance of the North Sumatra inspectorate, including the function of the auditor and leadership commitment. Using good governance as an indirect connection factor, the dependent variable is created.

The mediation model, sometimes referred to as the two-way model, was selected as the path analysis model for this investigation. In this mediation or intermediate paradigm, the variable Y_1 modifies the variable X to the variable Y_2 . The researcher looks for correlations among the four variables, starting with the aforementioned circumstances. The path analysis of the mediation model is the path analysis employed in this approach to determine the significance level (two paths). This relates to the variables X_1 , X_2 , which are linked to Y_1 before the outcomes are connected to Y_2 .

All 143 officials and workers from the Inspectorate Office of North Sumatra Province made up the study's entire population. Table 1 provides the specifics.

Table 1. Research Population at the Inspectorate of North Sumatra Province

No.	Employee	Amount
1.	Auditor Functional Position	91
2.	Secretariat Administrative Personnel	52
	Total	143

The Inspectorate of North Sumatra Province has two groups of personnel, each with a separate set of responsibilities, as shown in the above table. The first is the 91-person functional post of the auditor. This job is for auditors who work for the North Sumatra Province Government and perform auditing duties. The second is the Secretariat administrative staff, which consists of 52 individuals and is responsible for overseeing the administration of each office under the Inspectorate of North Sumatra Province. Based on the characteristics and goal of the research, the population of this research consists of up to 91 officials and workers who hold the functional position of auditors. The Slovin formula was employed in this study's sampling to ensure a 10% error rate.

The samples used in this investigation were 48 functional auditors, as determined by the calculations above. Because there are few samples and a complex model in this study, SmartPLS software is used for data analysis. SmartPLS employs random multiplication or bootstrapping. Thus, there won't be a problem with the normalcy assumption. Moreover, because SmartPLS uses bootstrapping, it may be used for research with small sample sizes because it does not require a minimum number of samples. The measurement model, also known as the "outer model," and the structural model, sometimes known as the "inner model," make up PLS-SEM analysis.

RESULTS

Information for readers on human resources owned by the inspectorate of the province of North Sumatra is described as important responder data. To comprehend and analyze research problems, particularly those pertaining to the performance of inspectorate staff, it is necessary to describe these respondents. Gender, age, and educational attainment are mentioned in the study's description of the respondents.

Table 2. Characteristics of Respondents

	Frequency	Percentage
Gender		
Man	23	48,3%
Women	25	51,7%
Total	48	100 %
Age		
20-30 Years	1	1,7 %
31-40 Years	9	20,0 %
41-50 Years	24	45,0 %
>51 Years	14	33,3%
Total	48	100 %
Education		
SMA/Equivalent	0	0 %
D-3	4	6,7 %
S-1	33	65,0 %
S-2	11	25,3%
Total	48	100%

Source: Results of SPSS data processing version 2018

Male respondents made up 23 individuals, or 8.3% of the total, while female respondents made up 25 individuals, or 51.7% of the total. Men and women are almost evenly represented in the distribution of respondents by gender. In other words, the situation shows that the gender-proportionate personnel resources available to the North Sumatra provincial inspectorate are adequate.

According to the aforementioned data, the plurality of respondents—24 individuals, or 45%—were between the ages of 41 and 50. Ages > 51, represented by 14 individuals, or 33.3%, were the next group, followed by ages 31–40, represented by 9 people, or 20%, and ages 20–30, represented by 1 individual, or 1.7%. This graph demonstrates how experienced auditors make up the majority of responses by age group.

Based on the table above, it can be seen that the highest level of education of the respondents was in stratum 1, with 33 people, or 65%, followed by stratum 2 with 11 people, or 28.3%, and stratum 3 with 4 people, or 6.7%, and no respondents with high school education. This distribution of respondents shows that most of the auditors in the inspectorate environment of North Sumatra Province are from strata-1 and 2 backgrounds with a little D3 and none with a high school education. This condition shows that professionalism with consideration of expertise is a part of work that is highly respected by the inspectorate of the province of North Sumatra.

Based on an analysis of the respondent's description, it was concluded that the inspectorate staff of North Sumatra Province should be able to demonstrate competent and professional performance with a balanced and adequate staff composition in terms of gender, age, and education. However, to find out the weak or less optimal performance of the North Sumatra Province inspectorate in carrying out their duties, an employee performance analysis was carried out through a bootstrapping analysis.

The bootstrapping analysis may be used to determine if a hypothesis is accepted or rejected in the PLS 3.0 smart unit. Based on the guidelines of the significance level and t-value, the outcomes of these tests are contrasted. If the t-value surpasses the t table or the significance threshold is less than 0.05 in this investigation, the hypothesis is accepted. For a total of 48 respondents, the t-table value is 1.96. The following are the study's bootstrapping findings:

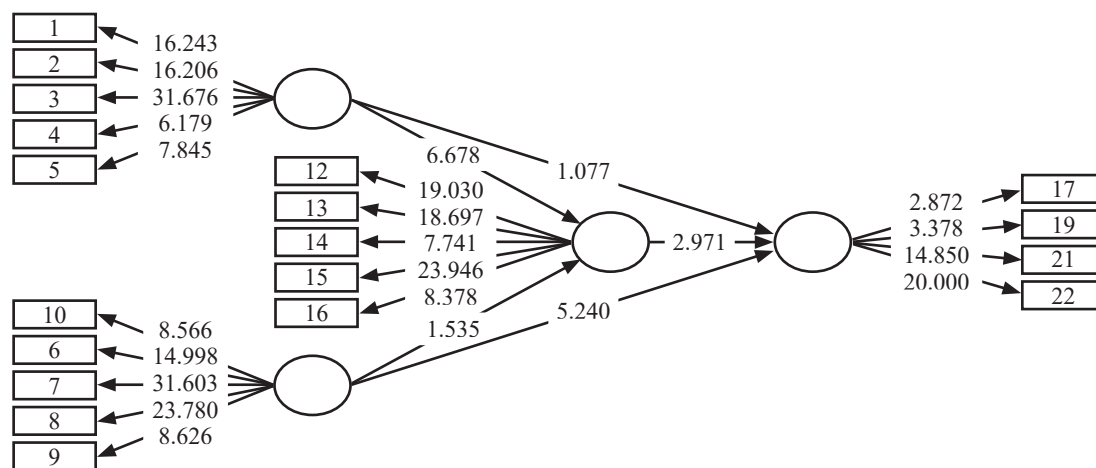

Figure 1. Path diagrams Bootstrapping

The findings of the analysis may be shown in the following table based on the test results bootstrapping:

Table 3. Path Results Coefficient

	Original Sample	Sample Means	Std. Deviation	T-Statistic	P Value	Hypothesis
Role of Auditor-Good Governance	0,964	0,943	0,144	6,678	0,000	Accepted
Leadership Commitment-Good Governance	-0,272	-0,250	0,177	1,535	0,125	Rejected
The Role of the Auditor- Performance Inspectorate	-0,171	-0,130	0,159	1,077	0,282	Rejected
Leader Commitment-Performance Inspectorate	0,699	0,728	0,133	5,240	0,000	Accepted
Good Governance –Inspectorate Performance	0,554	0,475	0,186	4,164	0,003	Accepted

DISCUSSION

The auditor's performance has an impact on good governance in the Inspectorate of North Sumatra Province, according to the first hypothesis being examined. As can be seen from the table above, the t-statistic for this hypothesis is 6.678, which is greater than the t-table of 1.96. This result's p-value, or level of significance, is 0.000 below 0.05. The first hypothesis, that the role of the auditor has an impact on the implementation of good governance in the Inspectorate of North Sumatra Province, is thus refuted in light of the criteria. Given the requirements, this hypothesis is valid. Also, this premise's sample origin is 0.964, which has a positive meaning. The findings support several studies that the role of the auditor has an impact on the implementation of good governance in the Inspectorate (Gramling & Schneider, 2018; Park et al., 2019). A good auditor's contribution to the inspectorate's effectiveness will also provide positive outcomes for the monitoring and inspection duties that must be performed in order to build an effective and professional government (Sofyani et al., 2022).

The second hypothesis is the influence of leadership commitment on the implementation of good governance in the Inspectorate of North Sumatra Province. Based on the table above, it can be seen that the t statistic for this hypothesis is 1.535, which is smaller than the t value of 1.96. Furthermore, the p-value for this hypothesis is 0.125, which is much larger than 0.05. Based on the requirements, this hypothesis is rejected; in other words, the leadership commitment has no effect on good governance. The results of this study are not in line with the view that the successful implementation of bureaucratic reform is determined by the existence of a leader in it, with the various inherent characteristics and responsibilities that they carry, demanding that leaders be more aggressive in innovating and contributing to the expected change process. In realizing excellent service, a leader must have the courage to make changes (Islam et al., 2018; Mesu et al., 2015). Positive changes made by a leader with the fortitude to do so will benefit the region he oversees. Real change must be implemented in accordance with the advancement of science and technology and the ebb and flow of the times (Chance, 2021).

The third hypothesis is the effect of the auditor's role on the performance of the Inspectorate of North Sumatra Province. Based on the table above, it can be seen that the t statistic for the hypothesis is 1.077; this number is smaller than the t value of 1.96. then the p-value for this hypothesis is 0.282, which is much greater than 0.05. Based on the requirements, this hypothesis is rejected; in other words, the role of the auditor does not affect the performance of the inspectorate of North Sumatra Province. The results of this study are not in line with the view that the successful implementation of bureaucratic reform is determined by the existence of a leader in it, with the various inherent characteristics and responsibilities that they carry, demanding that leaders be more aggressive in innovating and contributing to the expected change process (Alqudah et al., 2019; O'Leary & Stewart, 2007).

The fourth hypothesis is the influence of leadership commitment on the performance of the Inspectorate of North Sumatra Province. Based on the table above, it can be seen that the t statistic for this hypothesis is 5.240, which is greater than the t value of 1.96. Furthermore, the p-value for this hypothesis is 0.000, which is much smaller than 0.05. Based on the requirements, this hypothesis is accepted. Furthermore, the original sample for this hypothesis is 0.699, which has a positive meaning. Based on a number of these requirements, the leadership commitment has a positive and significant effect on the performance of the North Sumatra provincial inspectorate. The findings of this study are consistent with those of other studies (ex. Knotts & Houghton, 2021; Saleem et al., 2019) that demonstrate that leadership commitment enhances organizational performance by facilitating work through training, delivering adequate rewards or punishments to workers who break the rules, and making it simpler for workers to perform their jobs through adequate infrastructure and facilities.

The fifth hypothesis is the effect of good governance and application on the performance of the Inspectorate of North Sumatra Province. Based on the table above, it can be seen that the t statistic for this hypothesis is 4.164, which is greater than the t value of 1.96. then the p-value for this hypothesis is 0.003, which is much smaller than 0.05. Furthermore, the original sample in this hypothesis is 0.554, or positive; in other words, this hypothesis is accepted, namely that the implementation of good governance has a positive and significant effect on the performance of the Inspectorate of North Sumatra Province. The findings of this study support Mansoor's research (2021) and the view that a good government must open as many doors as possible so that all parties involved in government can participate or participate actively, that government operations must be carried out in a transparent manner, and that government implementation must be accountable. In other words, the implementation of good governance will determine the Inspectorate's performance in North Sumatra Province.

Table 4. Direct Influence Between Variables

Variable	Direct Effect			
	GG	%	KI	%
PA	6.678	36	1.077	6
KP	1.535	8	5,240	28
GG			4.164	22
Total	28		44	

Based on the table above, it can be seen that the effect of the auditor's role on good governance is 6.678 percent, or 36 percent, with the hypothesis accepted, while the direct effect of the leadership's commitment to good governance is 1.535 percent, or 8 percent, with the hypothesis rejected. Based on these results, the direct influence between the role of the auditor and the leadership's commitment to good governance is 28%. The findings of this study support those of Dzomira (2020), who found that good governance is a consequence of having a good auditor in that role.

Based on the table above, it can also be seen that the direct effect of the role of the auditor on the performance of the inspectorate is 1.077 or 6% with the hypothesis being rejected, while the direct effect of the leadership's commitment to the performance of the inspectorate is 5.240 or 28% with the hypothesis being accepted, and the direct effect of good governance on the performance of the inspectorate is 4.164 or 22%. Based on these results, the direct influence of the role of the auditor, leadership commitment, and good governance on inspectorate performance is 44%.

Indirect effect analysis is basically a feature of hypothesis testing using the path analysis method. This is because this analysis tests the hypothesis based on the relationship between variables in the presence of one intervening variable. In the context of this research, good governance is an intervening variable, where the exogenous variables, namely the role of the auditor (APIP) and leadership commitment, influence or not the performance of the inspectorate through its relationship with the implementation of governance indirectly. In line with the indirect analysis, this analysis also requires a t-count above the t-table, which is 1.96, and a significance level or p-value of less than 0.05 for hypothesis acceptance. The results can be seen in the following table:

Table 5. Indirect Effect

	Original Sample	Sample Means	Std. Deviation	T-Statistic	P Value	Hypothesis
Role of Auditor - Good Governance – Inspectorate Performance	0,534	0,457	0,211	2,526	0,012	Accepted
Leadership Commitment - Good Governance - Performance Inspectorate	-0,150	-0,123	0,107	1,413	0,158	Rejected

The sixth hypothesis is the effect of the role of the auditor on the performance of the inspectorate of North Sumatra Province through the implementation of good governance. Based on the table above, it can be seen that the t-statistic for this hypothesis is 2.526, which is greater than the t-table of 1.96. Furthermore, the p-value for this hypothesis is 0.012, which is much smaller than 0.05. Based on the requirements, this hypothesis is accepted; in other words, the role of the auditor affects the performance of the inspectorate of North Sumatra Province through good governance. Furthermore, the original sample in this hypothesis is 0.534, or positive; in other words, this hypothesis is accepted, namely that the role of the auditor has a positive and significant effect on the performance of the Inspectorate of North Sumatra Province through the application of good governance. The results of this study support several studies (Endri, 2020; Ibrani et al., 2020), including those that show that the inspectorate's performance will be good, with integrity, professional, and of good quality if the auditors are able to show quality and professional performance as well as being supported by good governance. So, it was concluded that these three elements must be interrelated and support each other so that good government can be obtained.

The seventh hypothesis is the effect of leadership commitment on the performance of the Inspectorate of North Sumatra Province through the implementation of good governance. Based on the table above, it can be seen that the t statistic for this hypothesis is 1.413, which is smaller than the t value of 1.96. then the p-value for this hypothesis is 0.158, which is much greater than 0.05. In other words, this hypothesis is rejected, namely, that the leadership commitment does not affect the performance of the Inspectorate of North Sumatra Province through the implementation of good governance. Based on the results above, the variables of good governance were not able to mediate well between the variables of leadership commitment and inspectorate performance. The existence of variables related to good governance did not have much effect on this study. In other words, anything that happens related to the performance of the inspectorate will not affect the leadership's commitment and implementation of good governance (Jain & Duggal, 2018; Saleem et al., 2019).

The equations obtained from the results of the analysis through bootstrapping are as follows:

$$AND_1 = 2,526X_1 - 1,413X_2 \dots\dots\dots(1)$$

From the path equation above, it can be seen that the indirect effect of each variable X on variable Y More details can be seen in the following table:

Table 6. Indirect Influence Between Variables

Variabel	indirect influence	
	KI	%
PP,GG	2.526	0.64
KP,GG	1.413	0.36
Total	0.28	

Based on the table above, it can also be seen that the indirect effect of the role of the auditor on inspectorate performance through good governance is 2526, or 64%, with the hypothesis accepted, while the indirect effect of leadership commitment on inspectorate performance through good governance is 1.413, or 36%, with the hypothesis rejected. Based on these results, the indirect effect between the role of the auditor and the leadership's commitment to inspectorate performance through good governance is 28%.

CONCLUSION

To improve the quality of findings and the role of the auditor, or APIP, good time management is needed to manage workload, deadlines, and the report processing process, which has the potential to reduce audit quality. The inspectorate leader must consult with staff about the policies that will be implemented. In addition, leaders must be able to place organizational interests above personal interests, sacrifice in terms of personal choices, and support decisions that benefit the organization even though these decisions are not liked. In terms of application good governance, which is good cooperation or teamwork, is needed to eliminate opportunism at work. Regarding the improvement of the performance of the Inspectorate of North Sumatra Province, maximum effort is required for each job that is carried out and has near-perfect results.

REFERENCES

- Alqudah, H. M., Amran, N. A., & Hassan, H. 2019. Factors Affecting The Internal Auditors' Effectiveness In The Jordanian Public Sector: The Moderating Effect Of Task Complexity. *EuroMed Journal of Business*, 14(3), 251–273. <https://doi.org/10.1108/EMJB-03-2019-0049>
- Bastian, I. 2019. Scraping The Recurrent Findings: A Case Study Of Yogyakarta City Government, Indonesia. *Religación: Revista de Ciencias Sociales y Humanidades*, 4(15), 290–297.
- Chance, N. L. 2021. A Phenomenological Inquiry Into The Influence Of Crucible Experiences On The Leadership Development Of Black Women In Higher Education Senior Leadership. *Educational Management Administration & Leadership*, 49(4), 601–623.
- Dewi, K., Sriwijaya, U., Budiman, A. I., Sriwijaya, U., Puspita, Y., Sriwijaya, U., Imam, S., & Economic, F. (n.d.). The Determination of Audit Consideration at Public Accounting Firm's in Palembang City : Job Stress as a Mediation Variable. 11(3), 213–231.
- Dyhati, A. S., & Wahyudi, T. 2022. The Effect of Integrity, Objectivity and Management Support on the Effectiveness of Internal Audit of The Government Sector in The Covid-19 Pandemic Condition. *Journal of Accounting Finance and Auditing Studies (JAFAS)*, 197–219. <https://doi.org/10.32602/jafas.2022.033>
- Dzomira, S. 2020. Corporate Governance And Performance Of Audit Committee And Internal Audit Functions In An Emerging Economy's Public Sector. *Indian Journal of Corporate Governance*, 13(1), 85–98.
- Edi, E., & Enzelin, I. 2022. Analyzing the Effect of Accounting Ethics Toward the Quality of Financial Report. *Journal of Accounting Finance and Auditing Studies (JAFAS)*, 36–54. <https://doi.org/10.32602/jafas.2022.009>
- Endri, E. 2020. The Effect Of Task Complexity, Independence And Competence On The Quality Of Audit Results With Auditor Integrity As A Moderating Variable. *International Journal of Innovation, Creativity and Change*, 12(12).
- Gramling, A., & Schneider, A. 2018. Effects Of Reporting Relationship And Type Of Internal Control Deficiency On Internal Auditors' Internal Control Evaluations. *Managerial Auditing Journal*, 33(3), 318–335. <https://doi.org/10.1108/MAJ-07-2017-1606>
- Habbe, A. H., Rasyid, S., Arif, H., & Muda, I. 2019. Measuring Internal Auditor's Intention To Blow The Whistle (A Quasi-Experiment Of Internal Auditors In The Local Government). *Business: Theory and Practice*, 20, 224–233. <https://doi.org/10.3846/btp.2019.22>
<https://www.tribunnews.com/regional/2011/05/19/inspektorat-sumatera-utara-akui-kelemahan>
- Ibrani, E. Y., Faisal, F., Sukasari, N., & Handayani, Y. D. 2020. Determinants And Consequences Of Internal Auditor Quality On Regional Government Performance: An Empirical Investigation In Indonesia. *Calitatea*, 21(176), 87–92.
- Islam, T., Tariq, J., & Usman, B. 2018. Transformational Leadership And Four-Dimensional Commitment: Mediating Role Of Job Characteristics And Moderating Role Of Participative And Directive Leadership Styles. *Journal of Management Development*, 37(9–10), 666–683. <https://doi.org/10.1108/JMD-06-2017-0197>
- Jain, P., & Duggal, T. 2018. Transformational Leadership, Organizational Commitment, Emotional Intelligence And Job Autonomy: Empirical Analysis On The Moderating And Mediating Variables. *Management Research Review*, 41(9), 1033–1046. <https://doi.org/10.1108/MRR-01-2018-0029>

- Knotts, K. G., & Houghton, J. D. 2021. You Can't Make Me! The Role Of Self-Leadership In Enhancing Organizational Commitment And Work Engagement. *Leadership and Organization Development Journal*, 42(5), 748–762. <https://doi.org/10.1108/LODJ-10-2020-0436>
- Mansoor, M. 2021. Citizens' Trust In Government As A Function Of Good Governance And Government Agency's Provision Of Quality Information On Social Media During COVID-19. *Government Information Quarterly*, 38(4), 101597.
- Mesu, J., Sanders, K., & Riemsdijk, M. van. 2015. Transformational Leadership And Organisational Commitment In Manufacturing And Service Small To Medium-Sized Enterprises: The Moderating Effects Of Directive And Participative Leadership. *Personnel Review*, 44(6), 970–990. <https://doi.org/10.1108/PR-01-2014-0020>
- Muhammad, K. 2017. *Mewujudkan Good Governance di Pemerintah Kota Malang Melalui Implementasi Undang-undang No. 14 tahun 2008 tentang Keterbukaan Informasi Publik*. Publisia: Jurnal Ilmu Administrasi Publik, 2(2). <https://doi.org/10.26905/pjiap.v2i2.2021>
- O'Leary, C., & Stewart, J. 2007. Governance Factors Affecting Internal Auditors' Ethical Decision-Making: An Exploratory Study. *Managerial Auditing Journal*, 22(8), 787–808. <https://doi.org/10.1108/02686900710819643>
- Park, H. Y., Lee, H. Y., & Kim, J. W. 2019. Investment In Internal Auditing And Governance Characteristics: Evidence From Statutory Internal Auditors In South Korea. *Managerial Auditing Journal*, 34(5), 623–648. <https://doi.org/10.1108/MAJ-10-2017-1689>
- Pencawan. Yoseph. 2021. *BPK Temukan 121 Temuan Laporan Keuangan Sumut Termasuk Dana Covid*. Diakses dari <https://mediaindonesia.com/nusantara/383256/bpk-temukan-121-temuan-laporan-keuangan-sumut-termasuk-dana-covid>
- Rahayu, S., Yudi, S., & Rahayu, S. 2020. Internal Auditors Role Indicators And Their Support Of Good Governance. *Cogent Business and Management*, 7(1). <https://doi.org/10.1080/23311975.2020.1751020>
- Rumaijuk. Adolf. 2011. Inspektorat Sumatera Utara Akui Kelemahan diakses dari
- S, S., Azwardi, A., & Fadillah, M. 2020. The Effect of Independence, Integrity, and Professionalism on the Performance of Government External Auditors: Case Study on the Southern Sumatra Audit Board. *Journal of Accounting Finance and Auditing Studies (JAFAS)*, 6(3), 36–57. <https://doi.org/10.32602/jafas.2020.017>
- Saleem, M. A., Bhutta, Z. M., Nauman, M., & Zahra, S. 2019. Enhancing Performance And Commitment Through Leadership And Empowerment: An Emerging Economy Perspective. *International Journal of Bank Marketing*, 37(1), 303–322. <https://doi.org/10.1108/IJBM-02-2018-0037>
- Saptomo, W. L. Y., & Rimawati, E. 2020. Path Analisis Technology Acceptance Model pada Penerapan Blended Learning. *Jurnal Sains Dan Informatika*, 6(2), 130–138. <https://doi.org/10.34128/jsi.v6i2.235>
- Sofyani, H., Abu Hasan, H., & Saleh, Z. 2022. Internal Control Implementation In Higher Education Institutions: Determinants, Obstacles And Contributions Toward Governance Practices And Fraud Mitigation. *Journal of Financial Crime*, 29(1), 141-158.
- Steyn, J. C. 2020. Soft Skills Development In Entry-Level Internal Auditors: Perspectives From Practising Internal Auditors, Students And Facilitators In South Africa. *Higher Education, Skills and Work-Based Learning*, 11(2), 528–544. <https://doi.org/10.1108/HESWBL-06-2020-0129>
- Sugiyono. 2019. *Penelitian Kuantitatif, Kualitatif, R&D*. Bandung: Alfabeta.
- Suhayati, E. 2022. Auditor Workload and Its Implication on Auditor's Professional Ability. *Journal of Eastern European and Central Asian Research*, 9(1), 21–28. <https://doi.org/10.15549/jeecar.v9i1.869>
- Suwiryo, D. H., & Samsudin, A. 2021. The Performance Optimization Analysis Of Inspectorates Supervision Functions Regional Device Organization At Sukabumi Regency. *International Journal of Multi Science*, 2(07), 37-52.
- Tiro, M. A., Makassar, U. N., Sukarna, S., & Makassar, U. N. 2020. *Analisis Jalur*. January.
- Usman, E., Usman, A., & others. 2016. Leadership Styles in Budgeting Participation to Support Managerial Performance. *International Journal of Organizational Innovation*, 8(4), 251.
- Yendrawati, R., Ekonomi, F., & Yogyakarta, U. I. 2013. *Pengaruh Sistem Pengendalian Intern Dan Kapasitas*. Jaai, 17(2), 166–175.